



谷橋工業股份有限公司

Good Chief Industrial Co., Ltd.

▲ 涉谷築橋 • 前線未來 ▼

鋁擠型型錄









ADD：台中市豐原區三和路354巷97弄20號

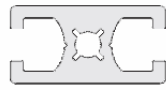
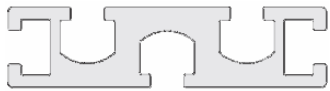

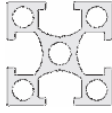
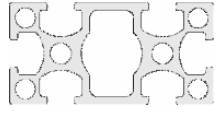
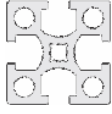

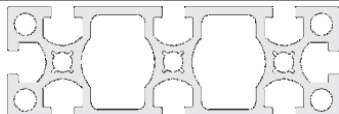

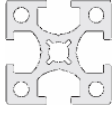
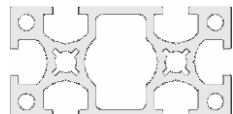

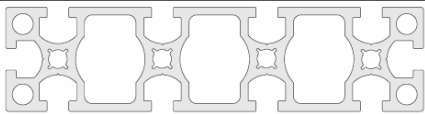

TEL：04-25345106 #182

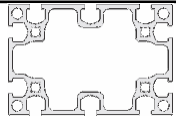
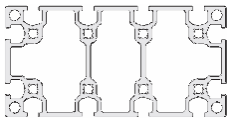

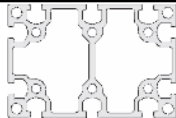
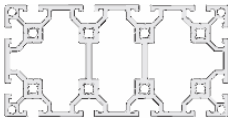
FAX：04-25332105

E-mail：gcad@goodchief.com.tw

<http://www.goodchief.com.tw>

項次	規格	型號	外觀	頁數
1	15*30	AF1530		5
2	15*30	AF1560		6
3	15*90	AF1590		7
4	20*20	AF2020		8
5	20*40	AF2040		9
6	30*30	AF3030		10
7	30*60	AF3060		11
8	30*90	AF3090		12
9	30*120	AF30120		13
10	40*40	AF4040		14
11	40*80	AF4080		15
12	40*120	AF40120		16

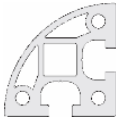
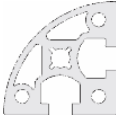
項次	規格	型號	外觀	頁數
13	40*160	AF40160		17
14	60*60	AF6060		18
15	60*90	AF6090		19
16	60*120	AF60120		20
17	80*80	AF8080		21
18	80*120	AF80120		22
19	80*160	AF80160		23
20	90*90	AF9090		24
21	66*30	AF6630		25
22	88*40	AF8840		26
23	60*60	AFR6660		27
24	20*20	AFR2020		28

項次	規格	型號	外觀	頁數
25	30*30	ARF3030		29
26	40*40	ARF4040-1		30
27	40*40	ARF4040-2		31
28	60*60	ARF6060		32
29	80*80	ARF8080		33

鋁擠型

AF1530

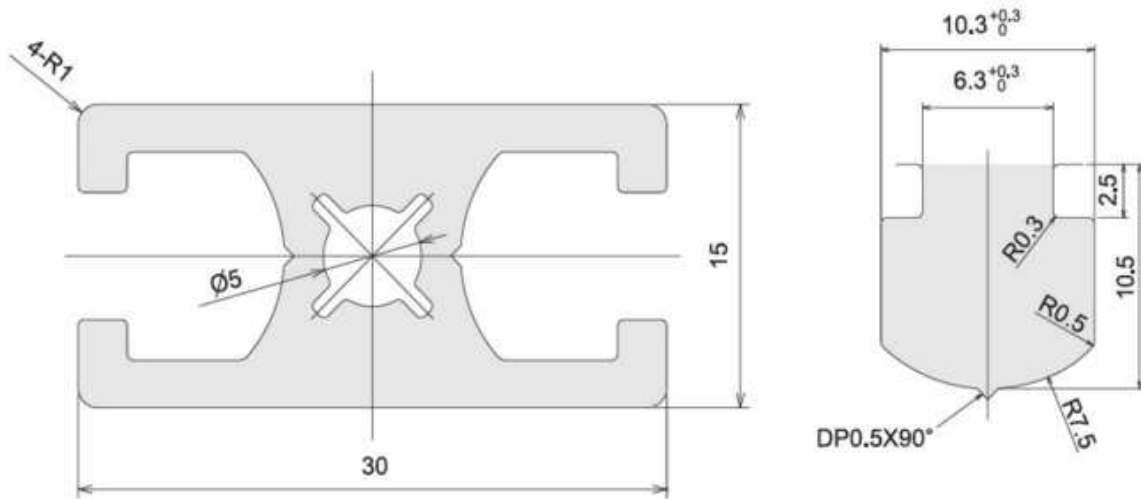

Technical Data (技術 Data)	
Material (材質)	A6N01S-T5 or A6063S-T5
Surface Processing (表面處理)	Anodized 陽極電鍍
Weight (重量)	0.65kg/m
Section Area (斷面積)	239.856mm ²
Second Section Moment	I _x =0.7x10cm
斷面2次 Moment	I _y =1.5x10cm
Specification (長度)	4,000mm / 6,000mm
Color (顏色)	Silver , Black
Application (用途)	機械結構、工作桌、機器外觀美化、門窗框架、感應器托架

鋁擠型

AF1560

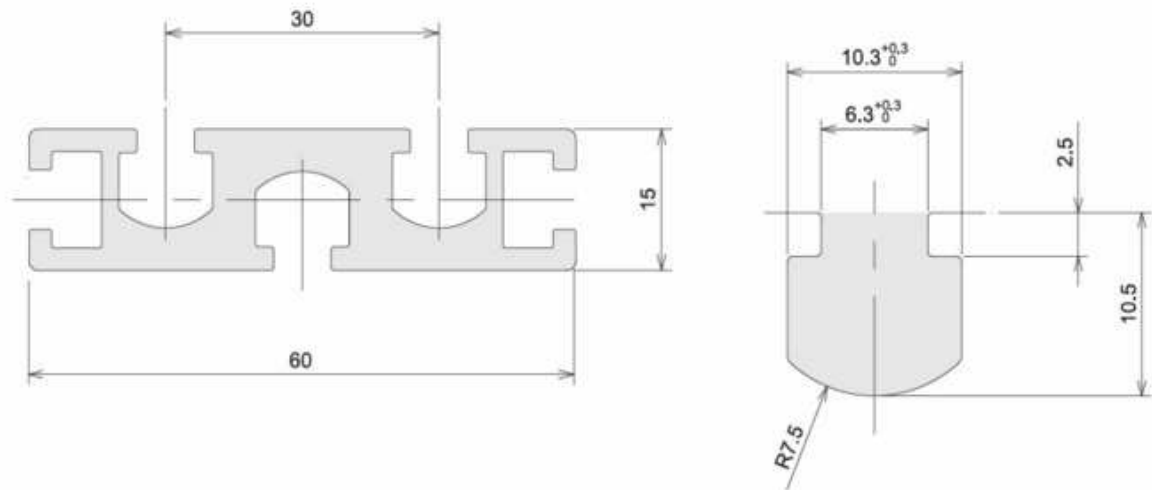

Technical Data (技術 Data)	
Material (材質)	A6N01S-T5 or A6063S-T5
Surface Processing (表面處理)	Anodized 陽極電鍍
Weight (重量)	1.3kg/m
Section Area (斷面積)	479.5mm ²
Second Section Moment	I _x =1.2x10cm
斷面2次 Moment	I _y =13.0x10cm
Specification (長度)	4,000mm / 6,000mm
Color (顏色)	Silver , Black
Application (用途)	機械結構、工作桌、機器外觀美化、門窗框架、感應器托架

鋁擠型

AF1590

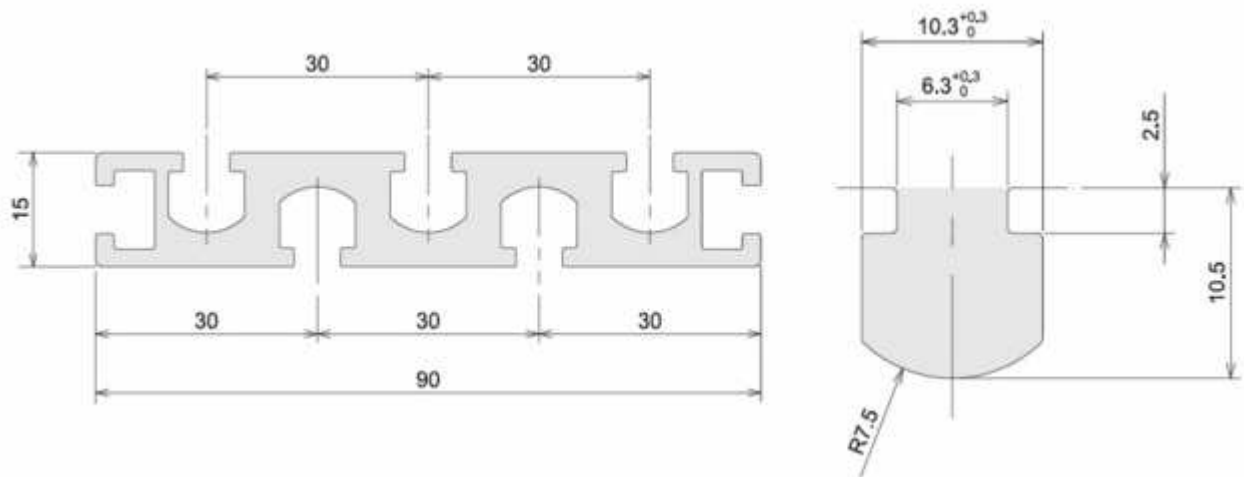

Technical Data (技術 Data)	
Material (材質)	A6N01S-T5 or A6063S-T5
Surface Processing (表面處理)	Anodized 陽極電鍍
Weight (重量)	2.02kg/m
Section Area (斷面積)	746.3mm ²
Second Section Moment	I _x =1.8x10cm
斷面2次 Moment	I _y =46.0x10cm
Specification (長度)	4,000mm / 6,000mm
Color (顏色)	Silver , Black
Application (用途)	機械結構、工作桌、機器外觀美化

鋁擠型

AF2020

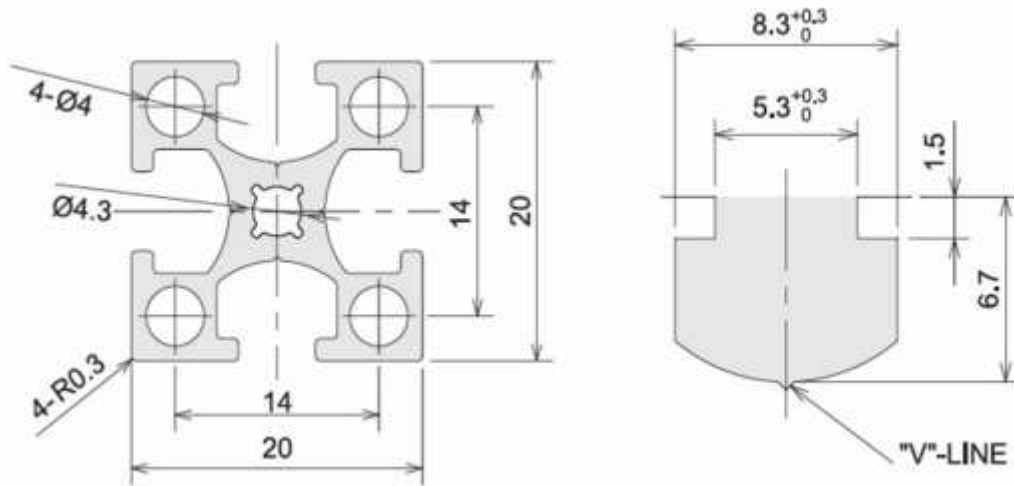

Technical Data (技術 Data)	
Material (材質)	A6N01S-T5 or A6063S-T5
Surface Processing (表面處理)	Anodized 陽極電鍍
Weight (重量)	0.39g/m
Section Area (斷面積)	145.94mm ²
Second Section Moment	I _x =0.59x10cm
斷面2次 Moment	I _y =0.59x10cm
Specification (長度)	4,000mm / 6,000mm
Color (顏色)	Silver , Black
Application (用途)	機械結構、工作桌、機器外觀美化

鋁擠型

AF2040

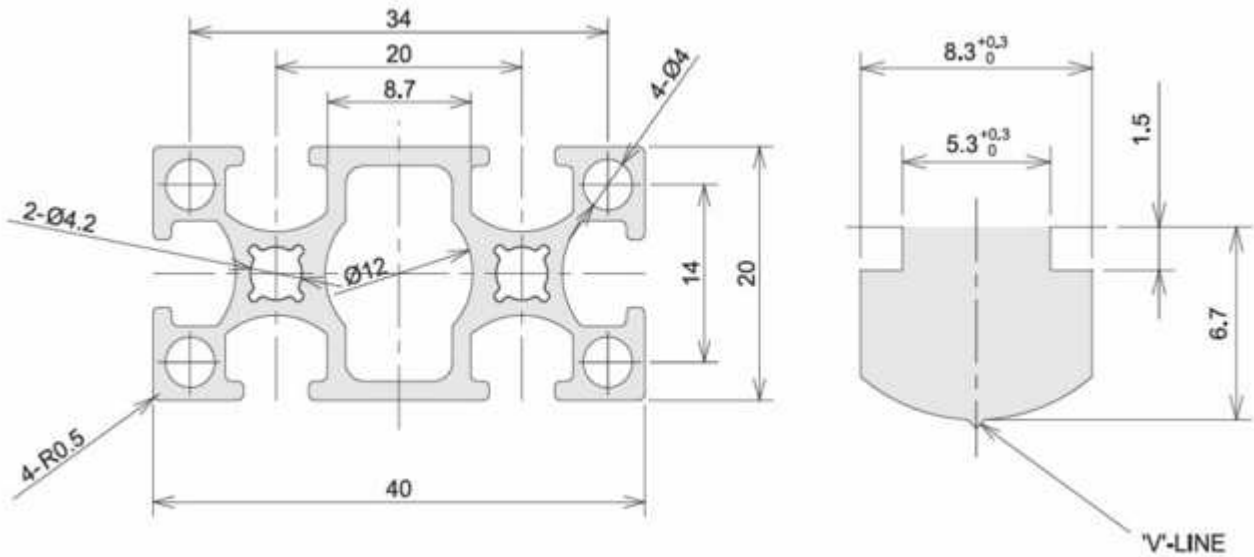

Technical Data (技術 Data)	
Material (材質)	A6N01S-T5 or A6063S-T5
Surface Processing (表面處理)	Anodized 陽極電鍍
Weight (重量)	0.74kg/m
Section Area (斷面積)	273.5mm ²
Second Section Moment	I _x =1.1x10cm
斷面2次 Moment	I _y =4.2x10cm
Specification (長度)	4,000mm / 6,000mm
Color (顏色)	Silver , Black
Application (用途)	機械結構、工作桌、機器外觀美化

鋁擠型

AF3030

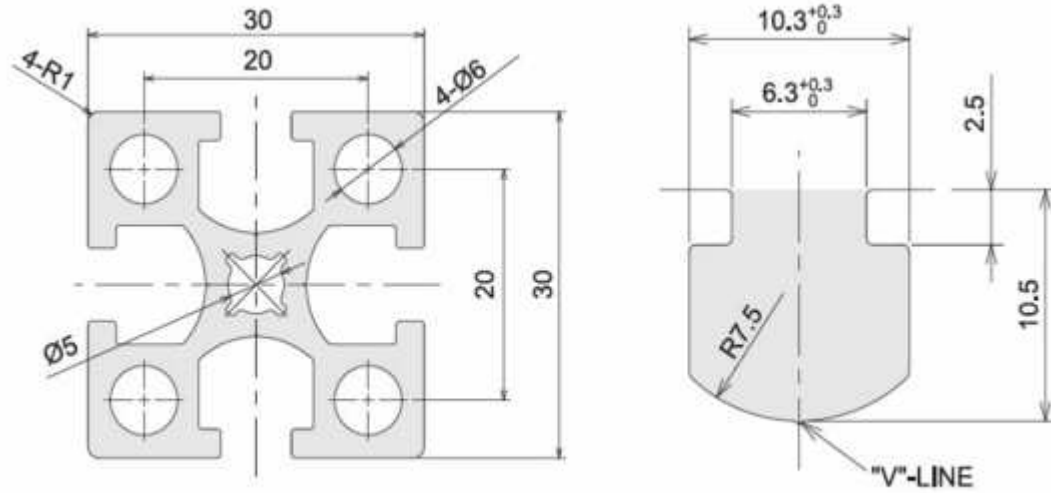

Technical Data (技術 Data)	
Material (材質)	A6N01S-T5 or A6063S-T5
Surface Processing (表面處理)	Anodized 陽極電鍍
Weight (重量)	1.07kg/m
Section Area (斷面積)	395.8mm ²
Second Section Moment	I _x =3.6x10cm
斷面2次 Moment	I _y =3.6x10cm
Specification (長度)	4,000mm / 6,000mm
Color (顏色)	Silver , Black
Application (用途)	機械結構、工作桌、機器外觀美化

鋁擠型

AF3060

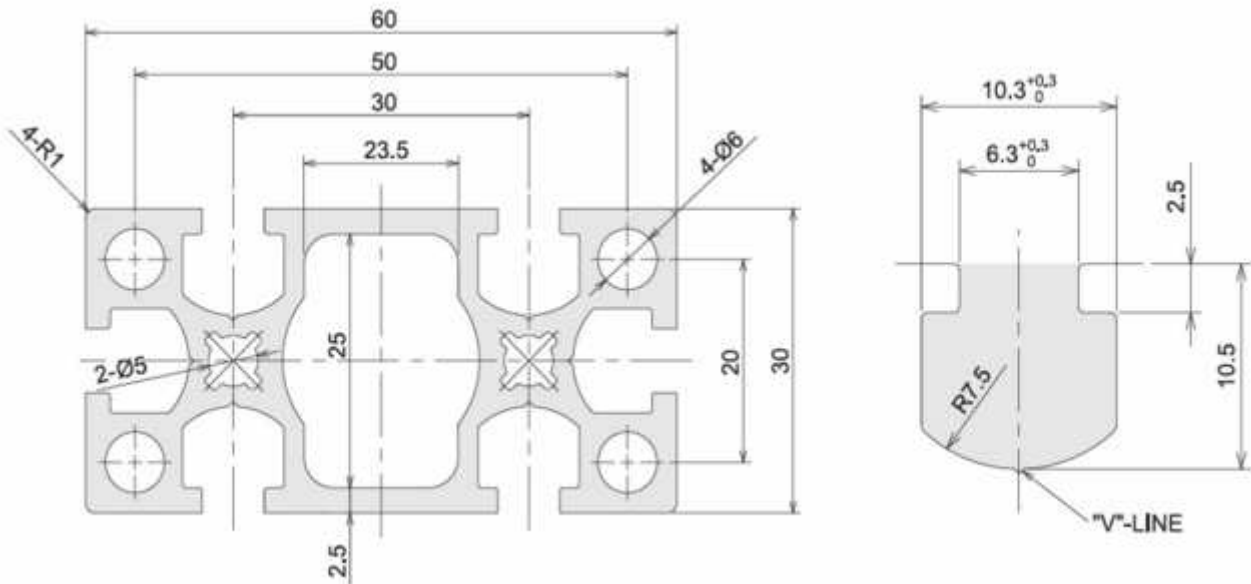

Technical Data (技術 Data)	
Material (材質)	A6N01S-T5 or A6063S-T5
Surface Processing (表面處理)	Anodized 陽極電鍍
Weight (重量)	1.8kg/m
Section Area (斷面積)	664.0mm ²
Second Section Moment	I _x =6.5x10cm
斷面2次 Moment	I _y =25.0x10cm
Specification (長度)	4,000mm / 6,000mm
Color (顏色)	Silver , Black
Application (用途)	機械結構、工作桌、機器外觀美化

鋁擠型

AF3090

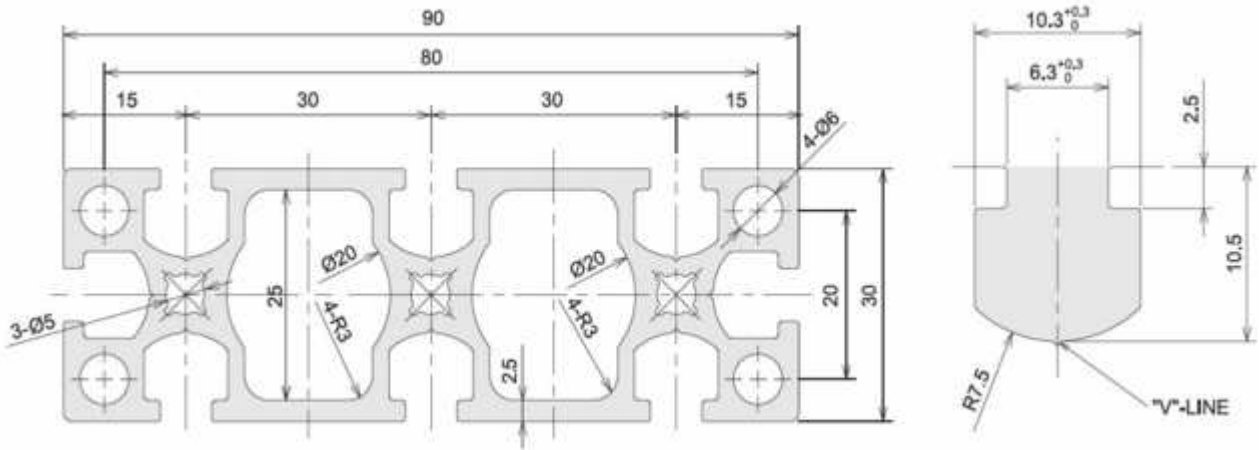

Technical Data (技術 Data)	
Material (材質)	A6N01S-T5 or A6063S-T5
Surface Processing (表面處理)	Anodized 陽極電鍍
Weight (重量)	2.543kg/m
Section Area (斷面積)	938.2mm ²
Second Section Moment	I _x =9.5x10cm
斷面2次 Moment	I _y =76.2x10cm
Specification (長度)	4,000mm / 6,000mm
Color (顏色)	Silver , Black
Application (用途)	機械結構、工作桌、機器外觀美化、門窗框架、感應器托架

鋁擠型

AF30120

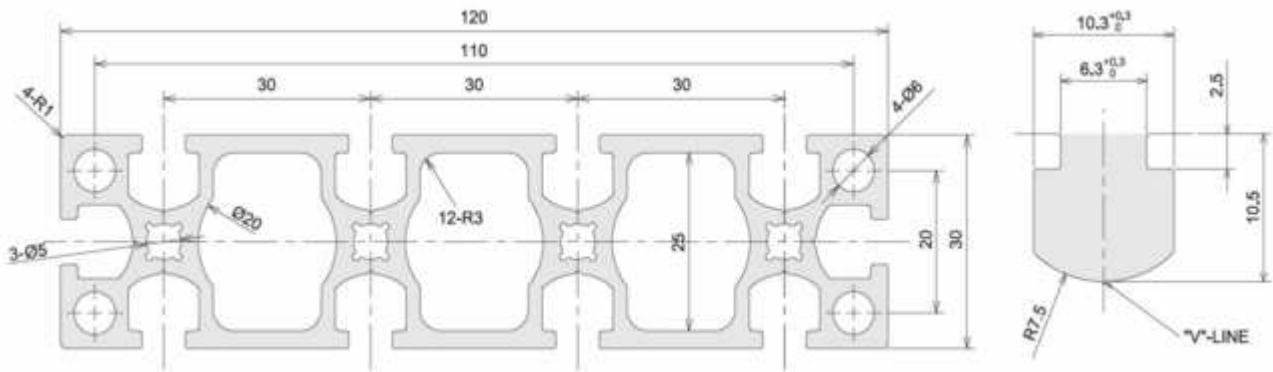

Technical Data (技術 Data)	
Material (材質)	A6N01S-T5 or A6063S-T5
Surface Processing (表面處理)	Anodized 陽極電鍍
Weight (重量)	3.279kg/m
Section Area (斷面積)	1209.8mm ²
Second Section Moment	I _x =12.4x10cm
斷面2次 Moment	I _y =169.7x10cm
Specification (長度)	4,000mm / 6,000mm
Color (顏色)	Silver , Black
Application (用途)	機械結構、工作桌、機器外觀美化、門窗框架、感應器托架

鋁擠型

AF4040

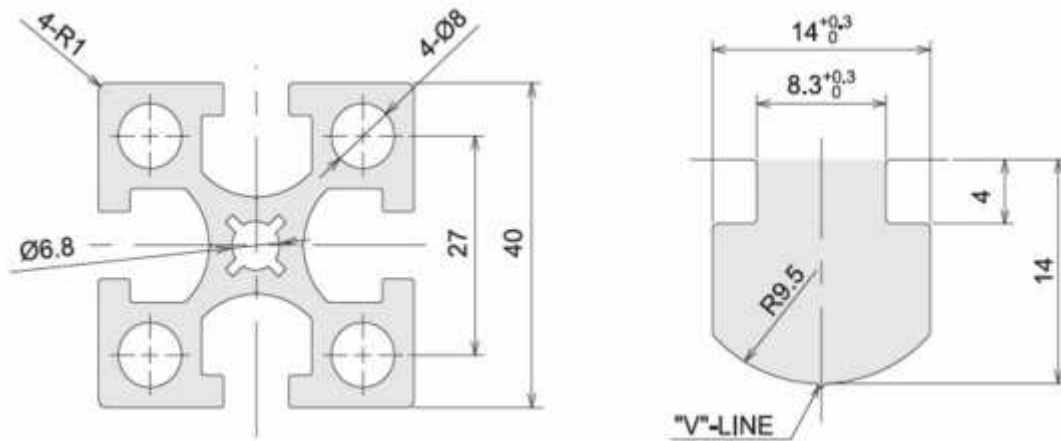

Technical Data (技術 Data)	
Material (材質)	A6N01S-T5 or A6063S-T5
Surface Processing (表面處理)	Anodized 陽極電鍍
Weight (重量)	1.909kg/m
Section Area (斷面積)	712.6mm ²
Second Section Moment	I _x =11.4x10cm
斷面2次 Moment	I _y =11.4x10cm
Specification (長度)	4,000mm / 6,000mm
Color (顏色)	Silver , Black
Application (用途)	機械結構、工作桌、機器外觀美化

鋁擠型

AF4080

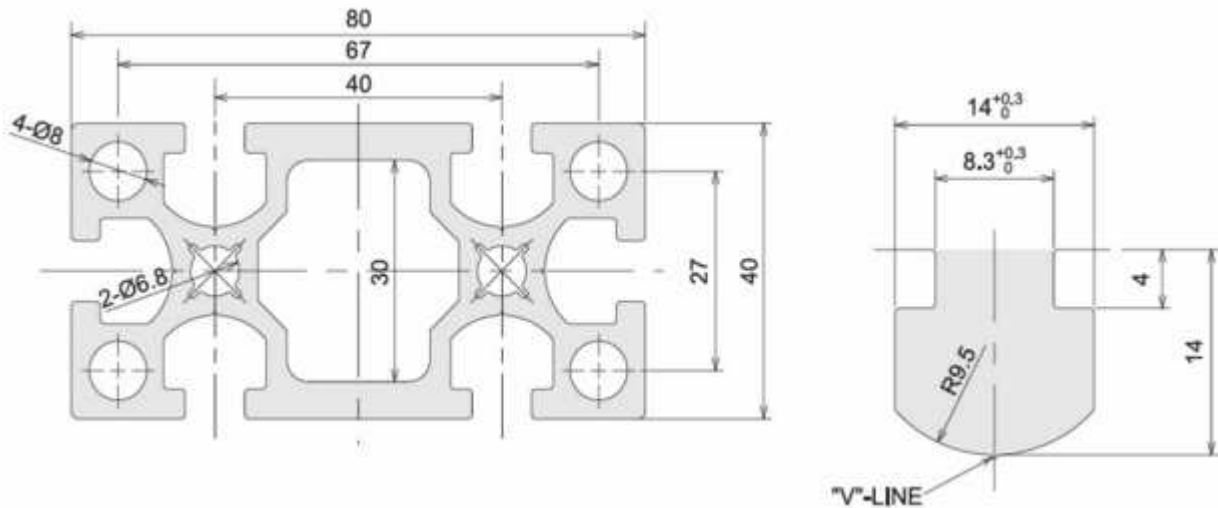

Technical Data (技術 Data)	
Material (材質)	A6N01S-T5 or A6063S-T5
Surface Processing (表面處理)	Anodized 陽極電鍍
Weight (重量)	3.39kg/m
Section Area (斷面積)	1.251mm ²
Second Section Moment	I _x =22.5x10cm
斷面2次 Moment	I _y =79.1x10cm
Specification (長度)	4,000mm / 6,000mm
Color (顏色)	Silver , Black
Application (用途)	機械結構、工作桌、機器外觀美化

鋁擠型

AF40120

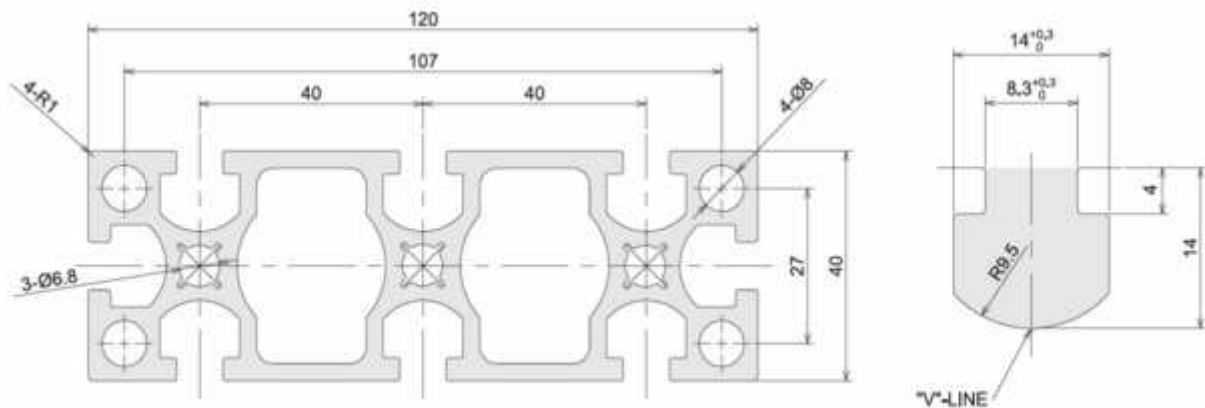

Technical Data (技術 Data)	
Material (材質)	A6N01S-T5 or A6063S-T5
Surface Processing (表面處理)	Anodized 陽極電鍍
Weight (重量)	4.55kg/m
Section Area (斷面積)	1.680mm ²
Second Section Moment	I _x =29.8x10cm
斷面2次 Moment	I _y =242.4x10cm
Specification (長度)	4,000mm / 6,000mm
Color (顏色)	Silver , Black
Application (用途)	機械結構、工作桌、機器外觀美化

鋁擠型

AF40160

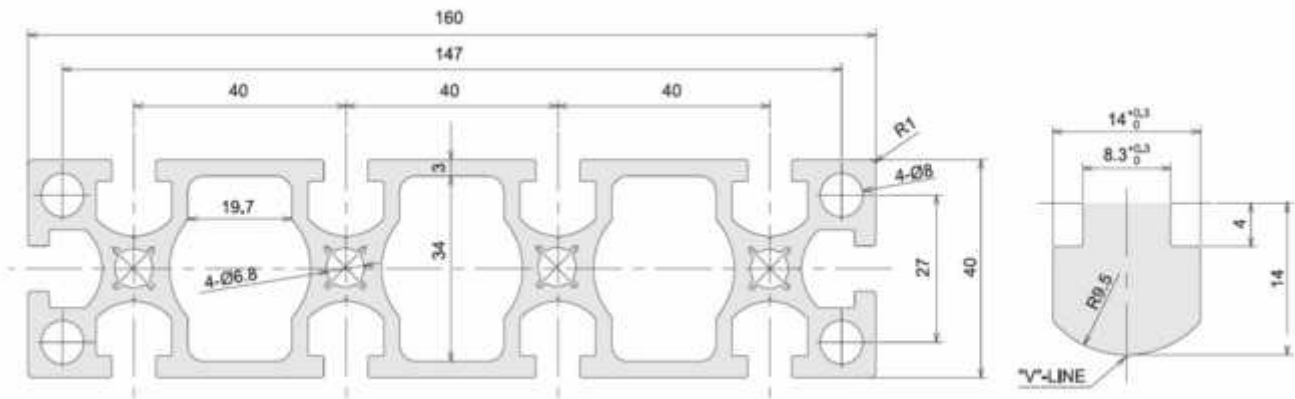

Technical Data (技術 Data)	
Material (材質)	A6N01S-T5 or A6063S-T5
Surface Processing (表面處理)	Anodized 陽極電鍍
Weight (重量)	5.837kg/m
Section Area (斷面積)	2.150mm ²
Second Section Moment	I _x =38.9x10cm
斷面2次 Moment	I _y =536.6x10cm
Specification (長度)	4,000mm / 6,000mm
Color (顏色)	Silver , Black
Application (用途)	機械結構、工作桌、機器外觀美化

鋁擠型

AF6060

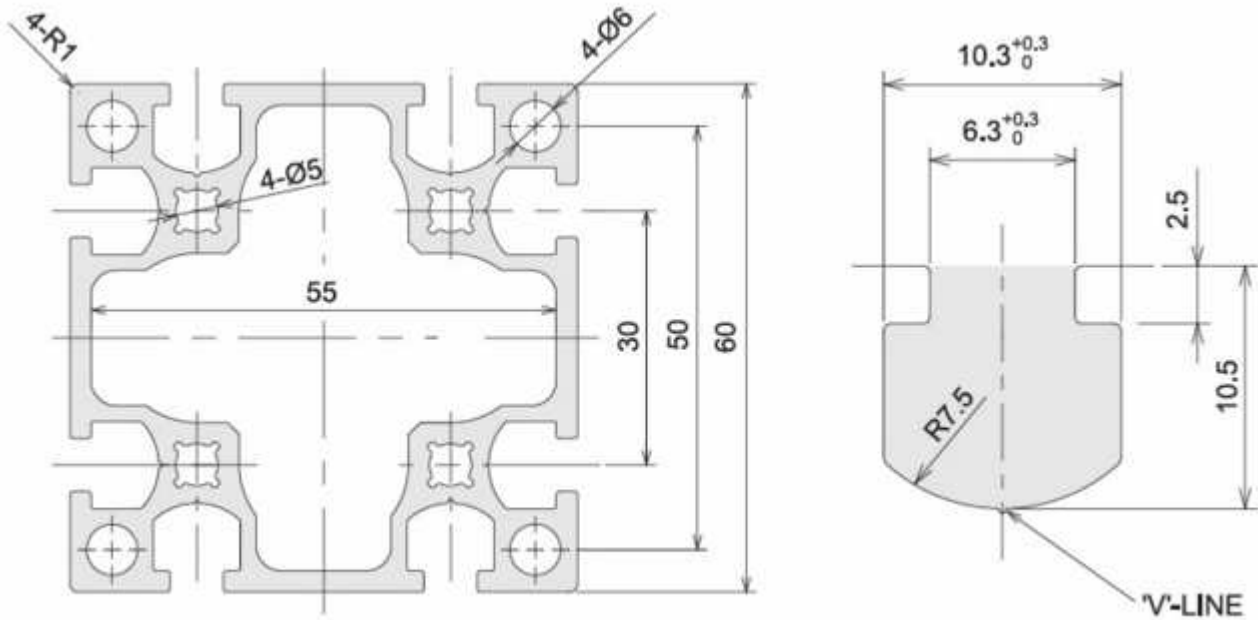

Technical Data (技術 Data)	
Material (材質)	A6N01S-T5 or A6063S-T5
Surface Processing (表面處理)	Anodized 陽極電鍍
Weight (重量)	2.718kg/m
Section Area (斷面積)	1,004.0mm ²
Second Section Moment	I _x =42.3x10cm
斷面2次 Moment	I _y =42.3x10cm
Specification (長度)	4,000mm / 6,000mm
Color (顏色)	Silver , Black
Application (用途)	機械結構、工作桌、機器外觀美化

鋁擠型

AF6090

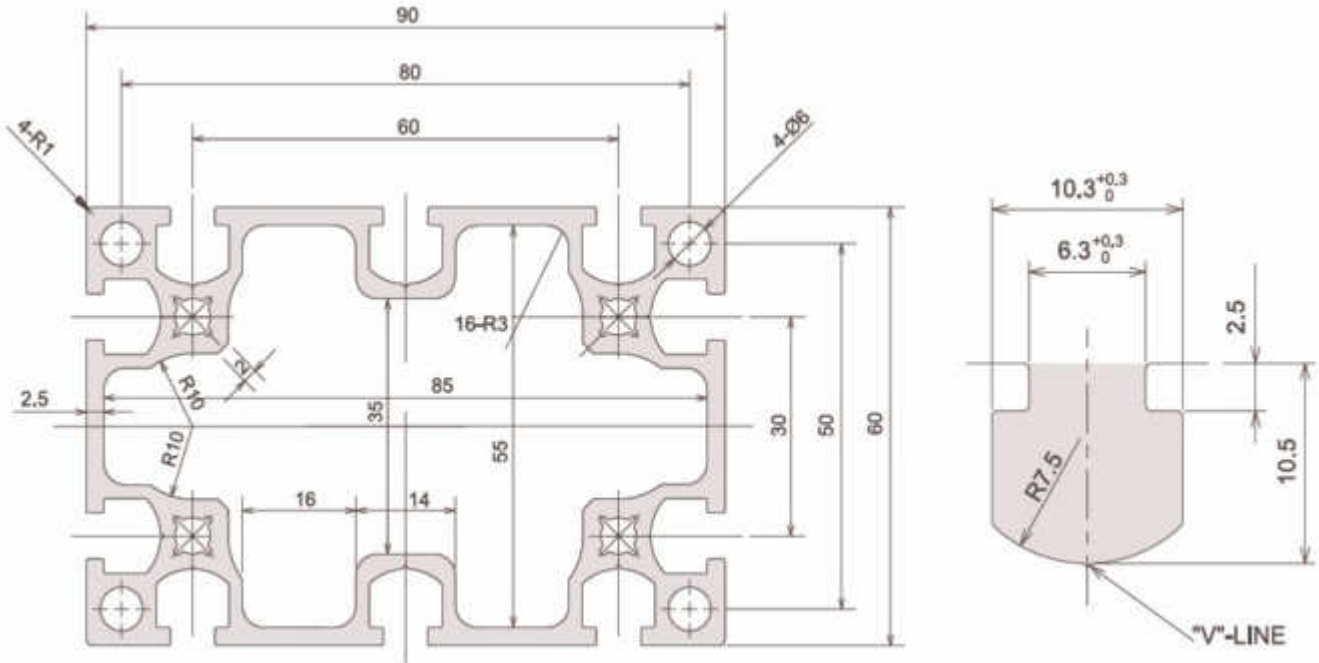

Technical Data (技術 Data)	
Material (材質)	A6N01S-T5 or A6063S-T5
Surface Processing (表面處理)	Anodized 陽極電鍍
Weight (重量)	3.385kg/m
Section Area (斷面積)	1,326.4mm ²
Second Section Moment	I _x =58.1x10cm
斷面2次 Moment	I _y =123.2x10cm
Specification (長度)	4,000mm / 6,000mm
Color (顏色)	Silver , Black
Application (用途)	機械結構、工作桌、機器外觀美化

鋁擠型

AF60120

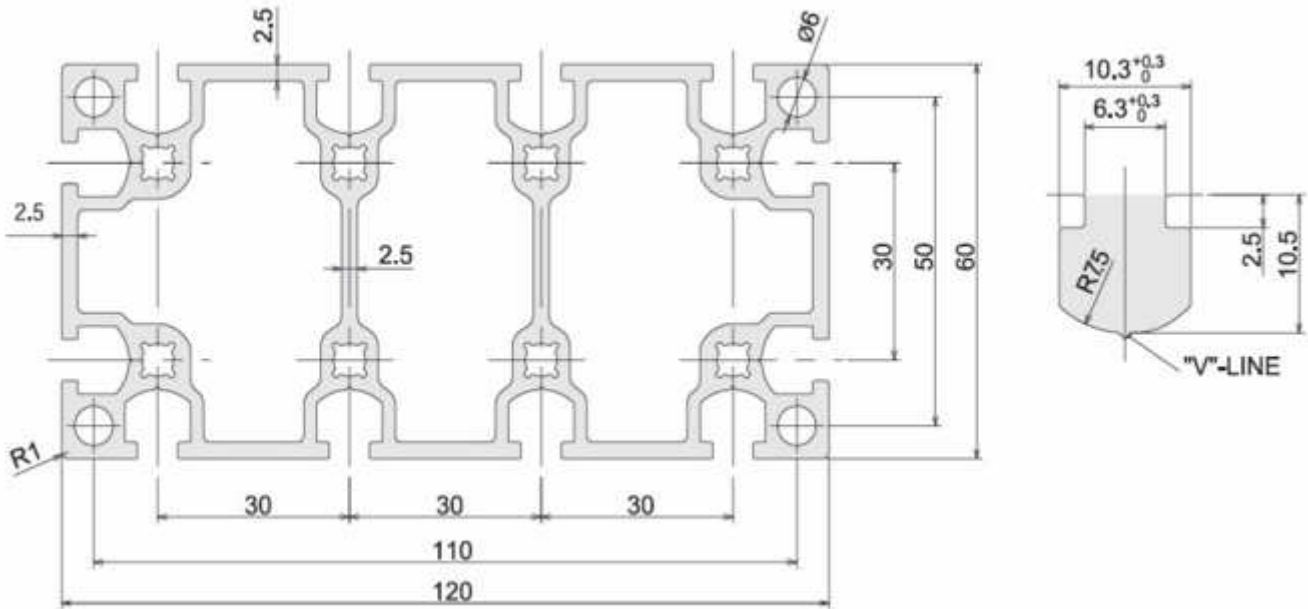

Technical Data (技術 Data)	
Material (材質)	A6N01S-T5 or A6063S-T5
Surface Processing (表面處理)	Anodized 陽極電鍍
Weight (重量)	4.679kg/m
Section Area (斷面積)	1724.3132mm ²
Second Section Moment	I _x =75.53x10cm
斷面2次 Moment	I _y =264.24x10cm
Specification (長度)	4,000mm / 6,000mm
Color (顏色)	Silver , Black
Application (用途)	機械結構、工作桌、機器外觀美化

鋁擠型

AF8080

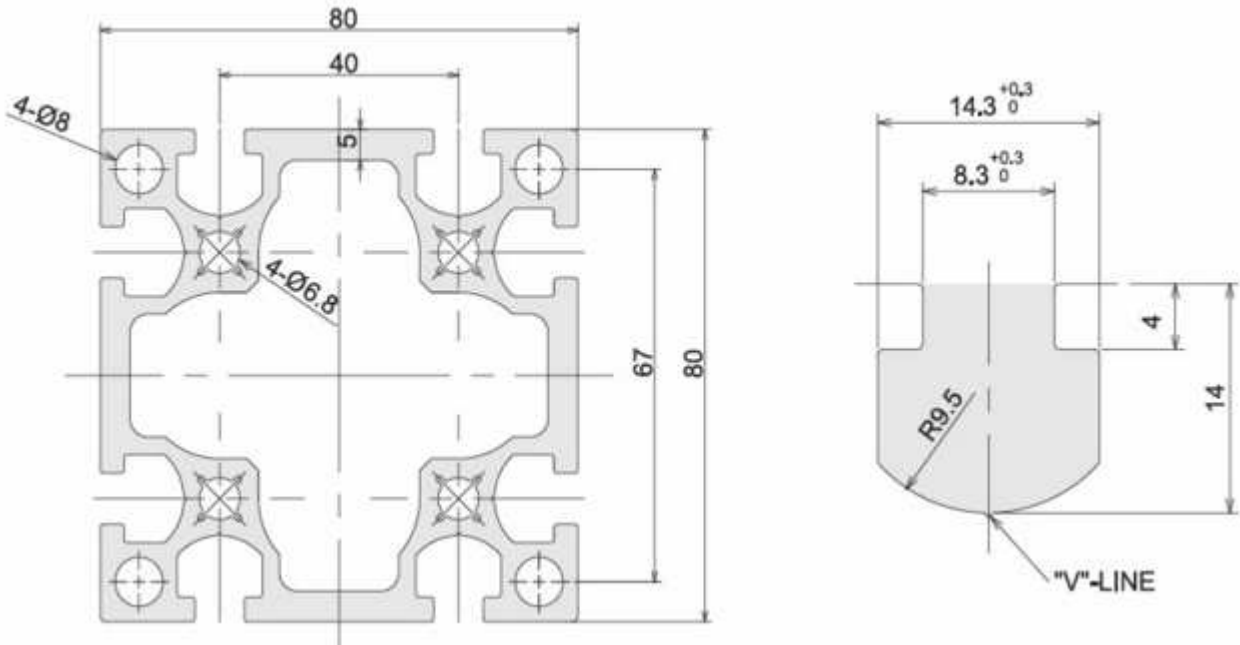

Technical Data (技術 Data)	
Material (材質)	A6N01S-T5 or A6063S-T5
Surface Processing (表面處理)	Anodized 陽極電鍍
Weight (重量)	5.238kg/m
Section Area (斷面積)	1,933.5mm ²
Second Section Moment	I _x =144.1x10cm
斷面2次 Moment	I _y =144.1x10cm
Specification (長度)	4,000mm / 6,000mm
Color (顏色)	Silver , Black
Application (用途)	機械結構、工作桌、機器外觀美化

鋁擠型

AF80120

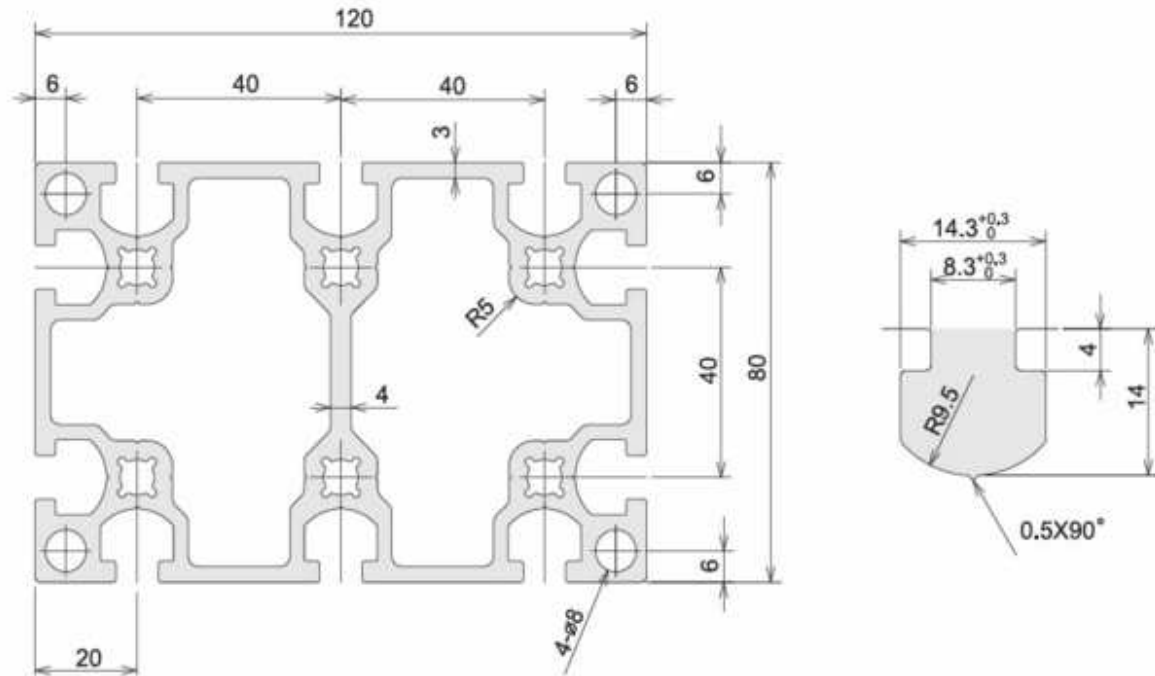

Technical Data (技術 Data)	
Material (材質)	A6N01S-T5 or A6063S-T5
Surface Processing (表面處理)	Anodized 陽極電鍍
Weight (重量)	6.87kg/m
Section Area (斷面積)	2,535.4mm ²
Second Section Moment	I _x =192.2x10cm
斷面2次 Moment	I _y =393.6x10cm
Specification (長度)	4,000mm / 6,000mm
Color (顏色)	Silver , Black
Application (用途)	機械結構、工作桌、機器外觀美化

鋁擠型

AF80160

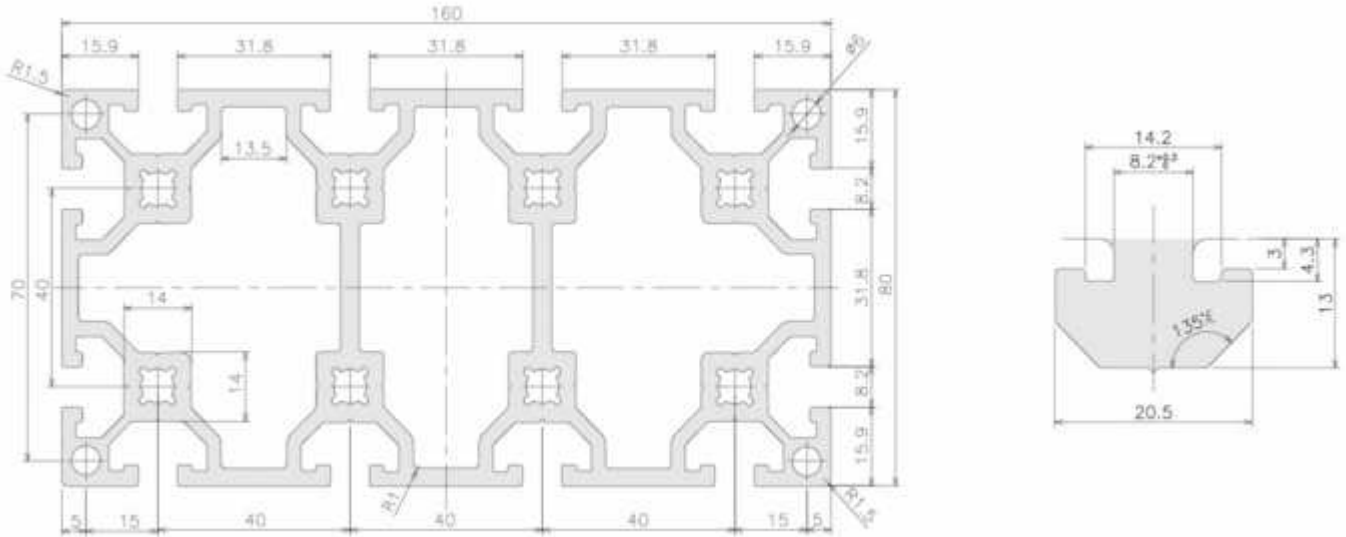

Technical Data (技術 Data)	
Material (材質)	A6N01S-T5 or A6063S-T5
Surface Processing (表面處理)	Anodized 陽極電鍍
Weight (重量)	9.227kg/m
Section Area (斷面積)	3404.7559mm ²
Second Section Moment	I _x =12532x10cm
斷面2次 Moment	I _y =862.6x10cm
Specification (長度)	4,000mm / 6,000mm
Color (顏色)	Silver , Black
Application (用途)	機械結構、工作桌、機器外觀美化

鋁擠型

AF9090

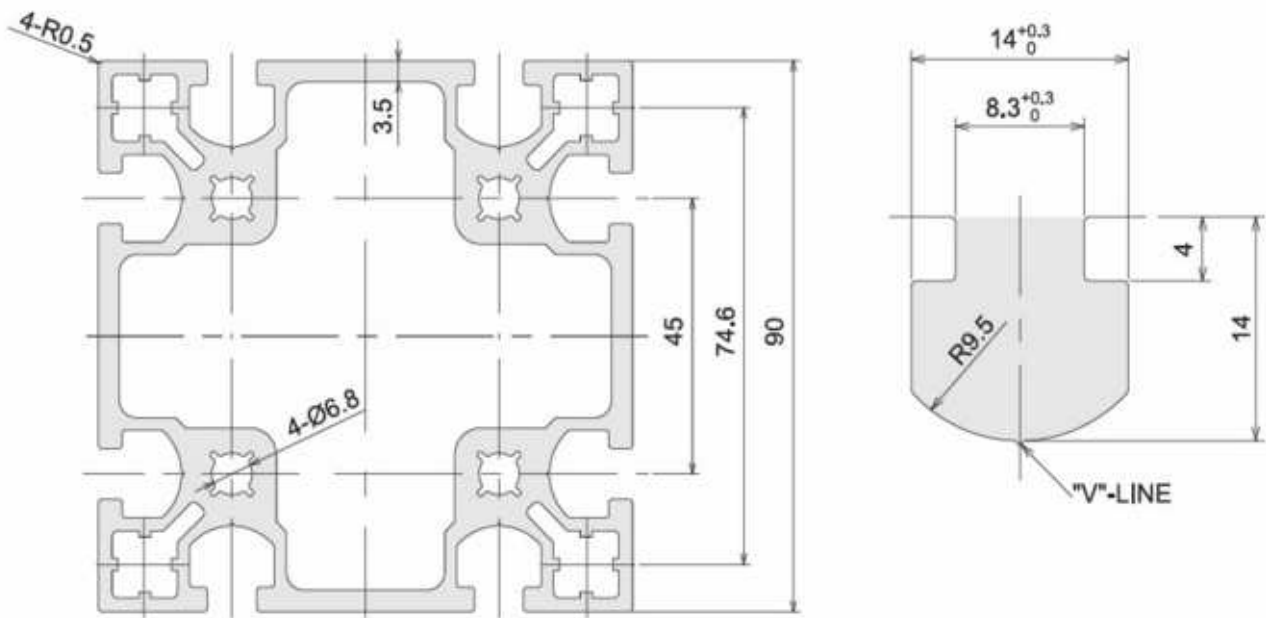

Technical Data (技術 Data)	
Material (材質)	A6N01S-T5 or A6063S-T5
Surface Processing (表面處理)	Anodized 陽極電鍍
Weight (重量)	5.862kg/m
Section Area (斷面積)	2,162.8mm ²
Second Section Moment	I _x =198.0x10cm
斷面2次 Moment	I _y =198.0x10cm
Specification (長度)	4,000mm / 6,000mm
Color (顏色)	Silver , Black
Application (用途)	機械結構、工作桌、機器外觀美化

鋁擠型

AF6630

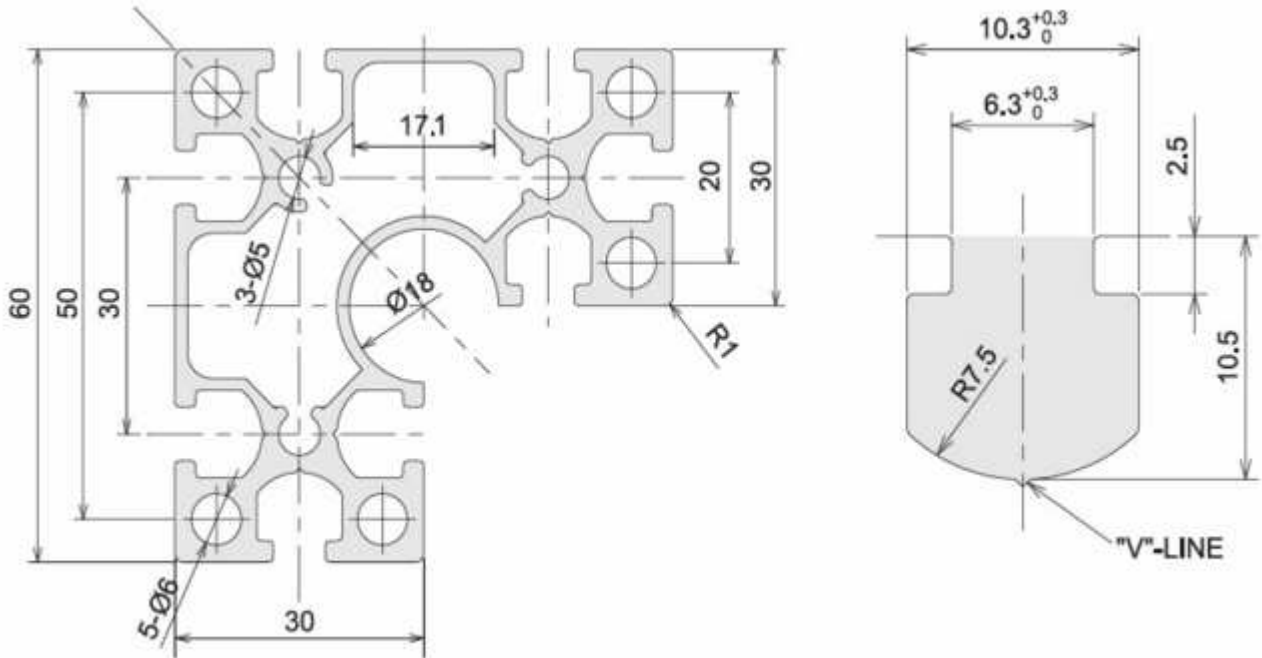

Technical Data (技術 Data)	
Material (材質)	A6N01S-T5 or A6063S-T5
Surface Processing (表面處理)	Anodized 陽極電鍍
Weight (重量)	2.18kg/m
Section Area (斷面積)	804.1mm ²
Second Section Moment	I _x =19.8x10cm
斷面2次 Moment	I _y =40.0x10cm
Specification (長度)	4,000mm / 6,000mm
Color (顏色)	Silver , Black
Application (用途)	腳架、機械結構、工作桌、機器外觀美化

鋁擠型

AF8840

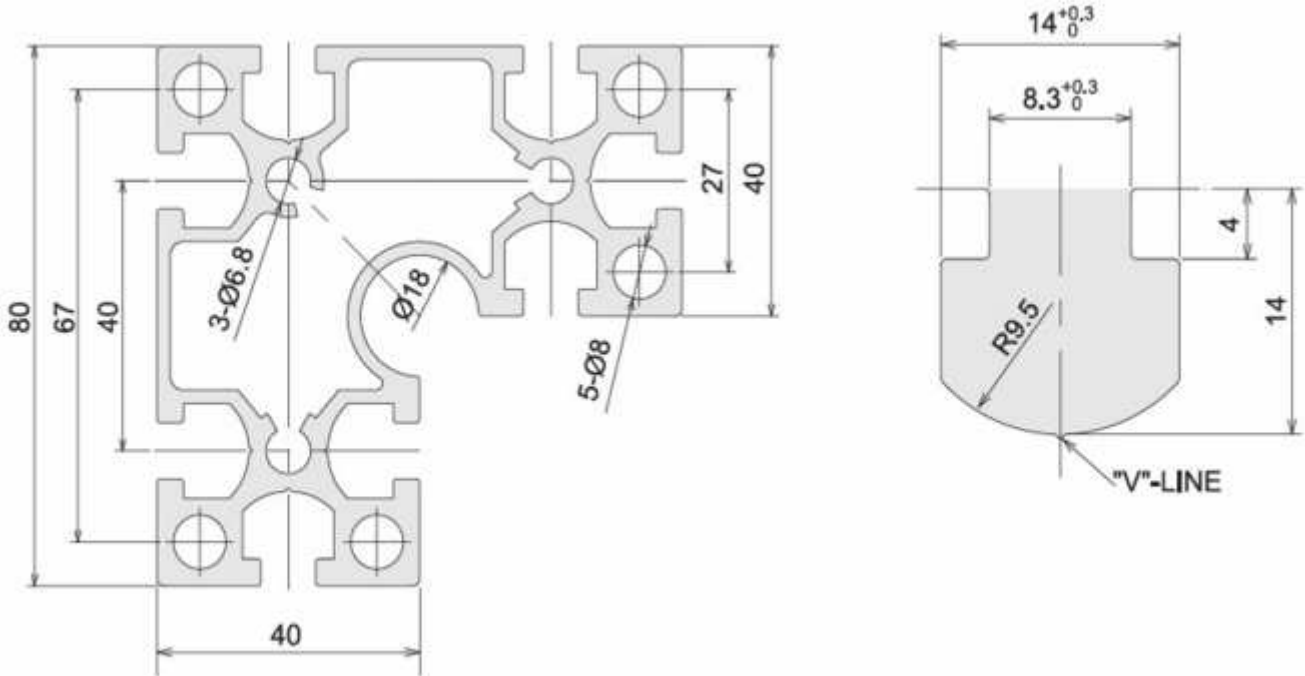

Technical Data (技術 Data)	
Material (材質)	A6N01S-T5 or A6063S-T5
Surface Processing (表面處理)	Anodized 陽極電鍍
Weight (重量)	4.01kg/m
Section Area (斷面積)	1,479.7mm ²
Second Section Moment	I _x =63.8x10cm
斷面2次 Moment	I _y =128.4x10cm
Specification (長度)	4,000mm / 6,000mm
Color (顏色)	Silver , Black
Application (用途)	腳架、機械結構、工作桌、機器外觀美化

鋁擠型

AFR6060

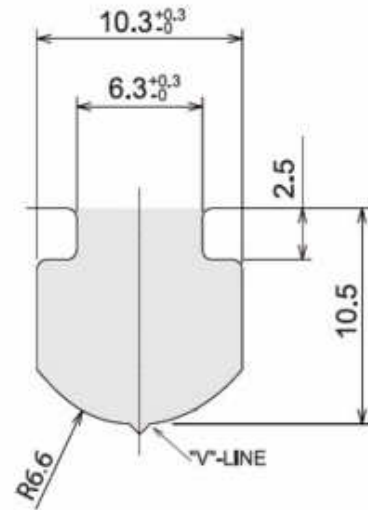
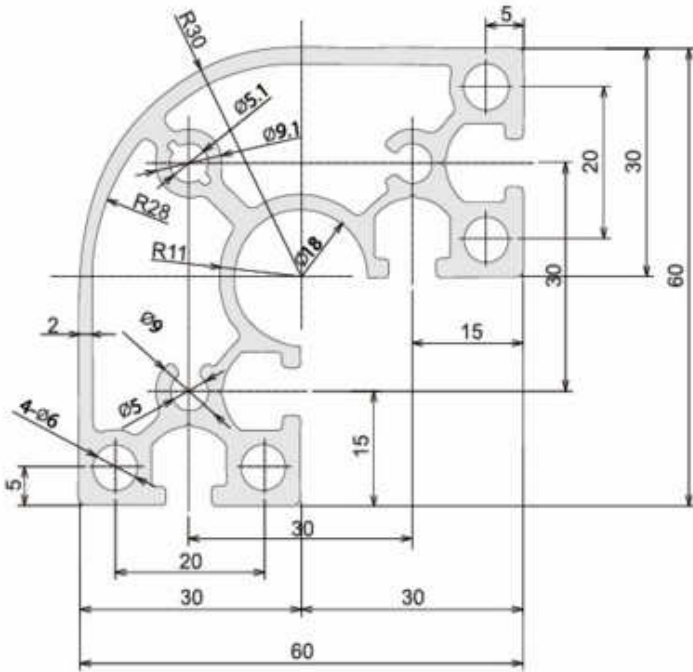

Technical Data (技術 Data)	
Material (材質)	A6N01S-T5 or A6063S-T5
Surface Processing (表面處理)	Anodized 陽極電鍍
Weight (重量)	2.1kg/m
Section Area (斷面積)	772.6mm ²
Second Section Moment	I _x =13.8x10cm
斷面2次 Moment	I _y =40.2x10cm
Specification (長度)	4,000mm / 6,000mm
Color (顏色)	Silver , Black
Application (用途)	機械結構、工作桌、機器外觀美化

鋁擠型

ARF2020

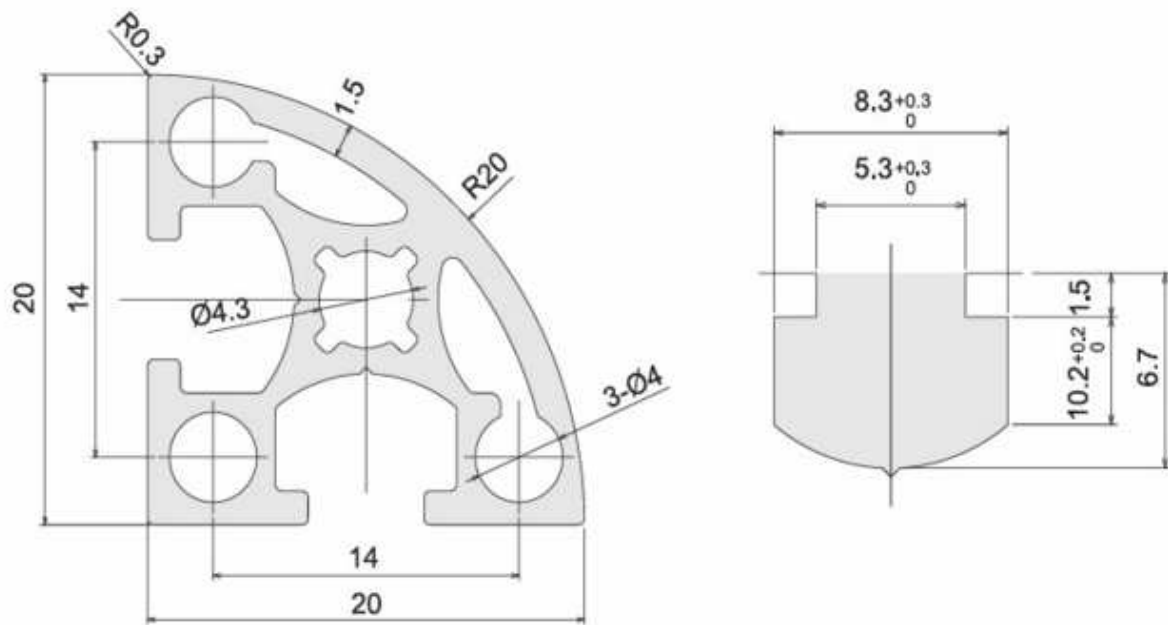

Technical Data (技術 Data)	
Material (材質)	A6N01S-T5 or A6063S-T5
Surface Processing (表面處理)	Anodized 陽極電鍍
Weight (重量)	0.356kg/m
Section Area (斷面積)	134.42mm ²
Second Section Moment	I _x =0.337x10cm
斷面2次 Moment	I _y =0.55x10cm
Specification (長度)	4,000mm / 6,000mm
Color (顏色)	Silver , Black
Application (用途)	機械結構、工作桌、機器外觀美化

鋁擠型

ARF3030

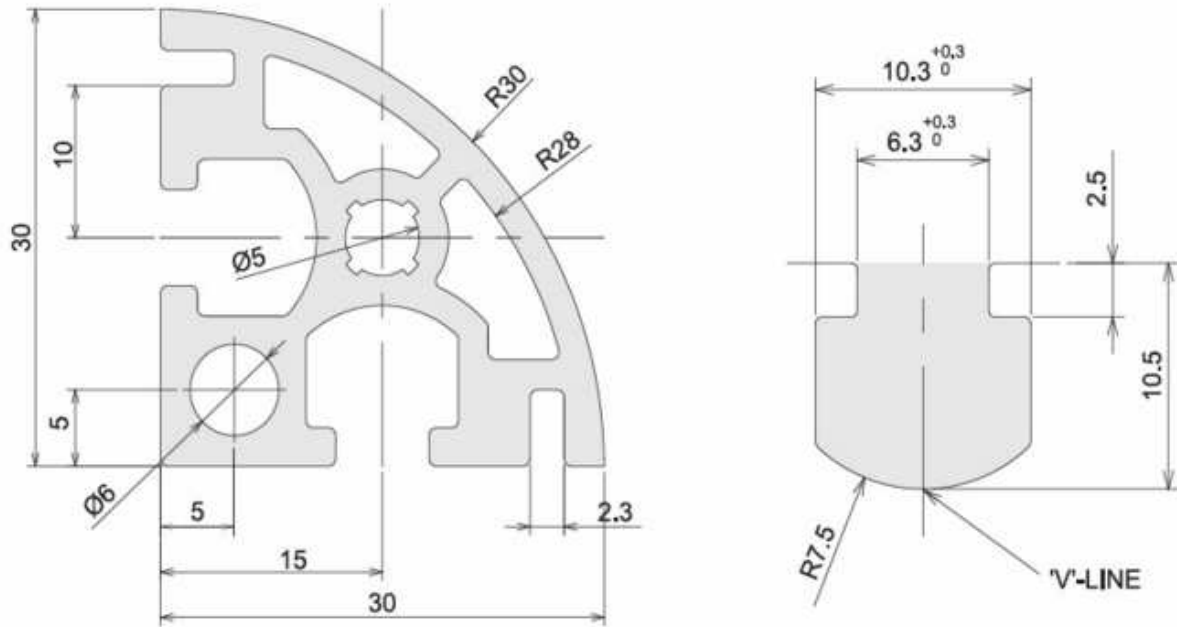

Technical Data (技術 Data)	
Material (材質)	A6N01S-T5 or A6063S-T5
Surface Processing (表面處理)	Anodized 陽極電鍍
Weight (重量)	0.94kg/m
Section Area (斷面積)	345.5mm ²
Second Section Moment	I _x =1.9x10cm
斷面2次 Moment	I _y =3.5x10cm
Specification (長度)	4,000mm / 6,000mm
Color (顏色)	Silver , Black
Application (用途)	機械結構、工作桌、機器外觀美化

鋁擠型

ARF4040-1

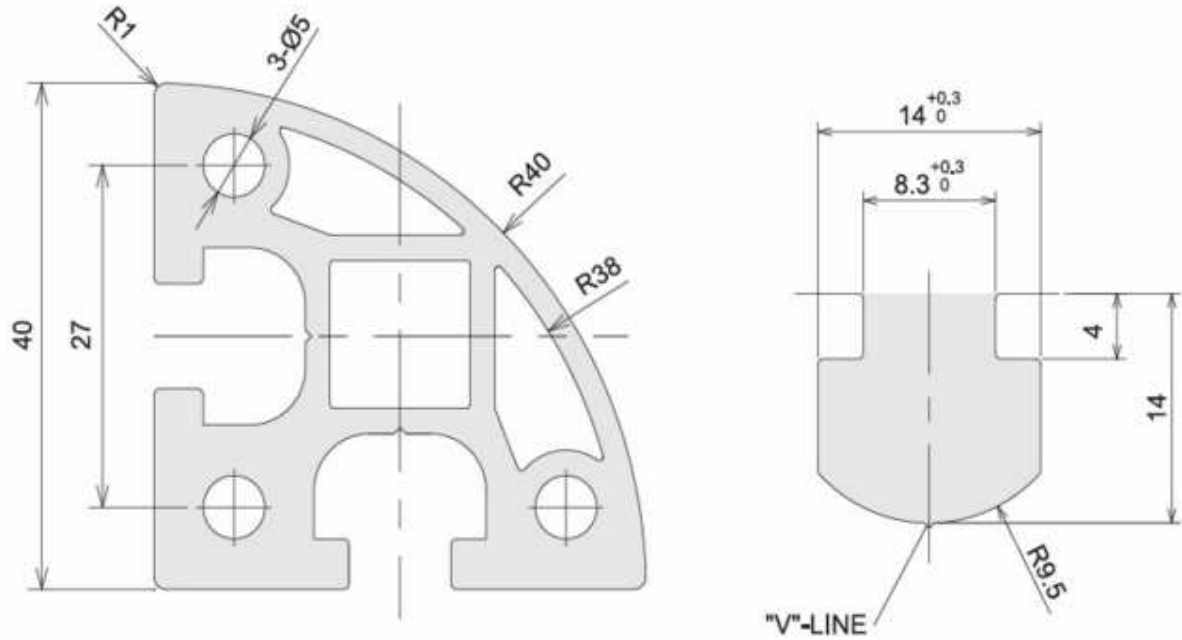

Technical Data (技術 Data)	
Material (材質)	A6N01S-T5 or A6063S-T5
Surface Processing (表面處理)	Anodized 陽極電鍍
Weight (重量)	1.71kg/m
Section Area (斷面積)	629.5mm ²
Second Section Moment	I _x =6.3x10cm
斷面2次 Moment	I _y =11.9x10cm
Specification (長度)	4,000mm / 6,000mm
Color (顏色)	Silver , Black
Application (用途)	機械結構、工作桌、機器外觀美化

鋁擠型

ARF4040-2

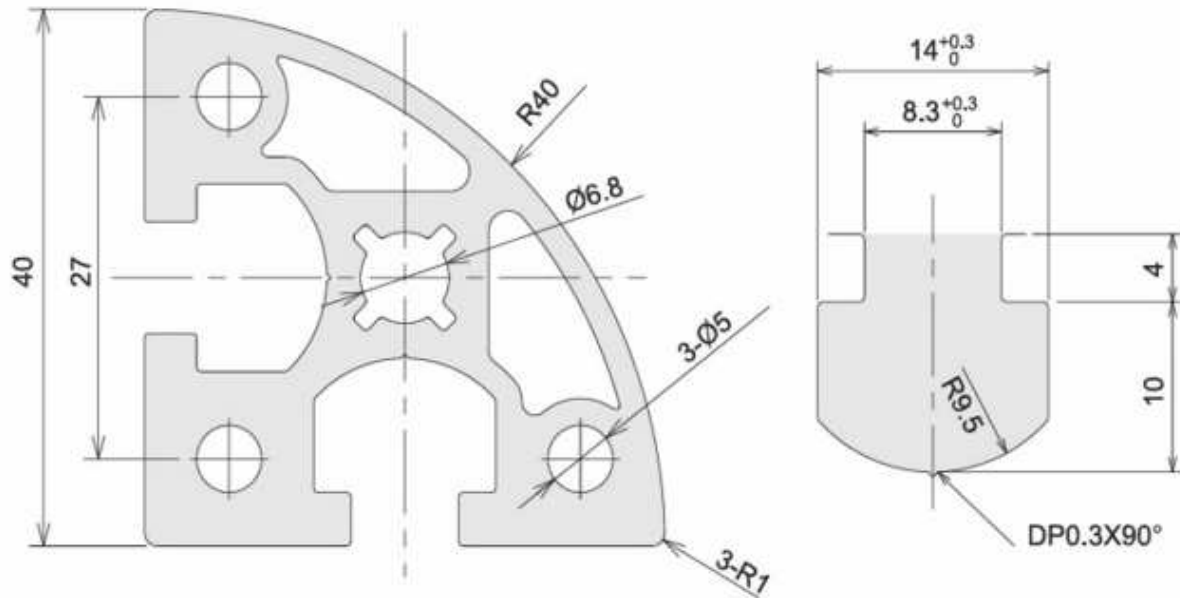

Technical Data (技術 Data)	
Material (材質)	A6N01S-T5 or A6063S-T5
Surface Processing (表面處理)	Anodized 陽極電鍍
Weight (重量)	1.751kg/m
Section Area (斷面積)	645.97mm ²
Second Section Moment	I _x =6.378x10cm
斷面2次 Moment	I _y =11.7x10cm
Specification (長度)	4,000mm / 6,000mm
Color (顏色)	Silver , Black
Application (用途)	機械結構、工作桌、機器外觀美化

鋁擠型

ARF6060

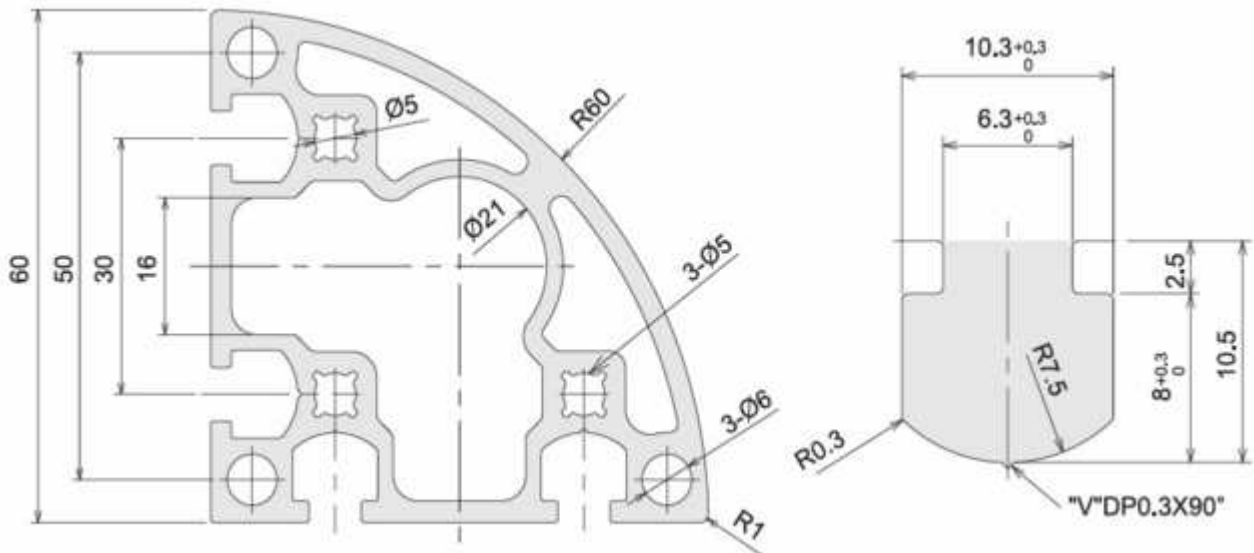

Technical Data (技術 Data)	
Material (材質)	A6N01S-T5 or A6063S-T5
Surface Processing (表面處理)	Anodized 陽極電鍍
Weight (重量)	2.54kg/m
Section Area (斷面積)	935.965mm ²
Second Section Moment	I _x =22.4x10cm
斷面2次 Moment	I _y =41.8x10cm
Specification (長度)	4,000mm / 6,000mm
Color (顏色)	Silver , Black
Application (用途)	機械結構、工作桌、機器外觀美化

鋁擠型

ARF8080

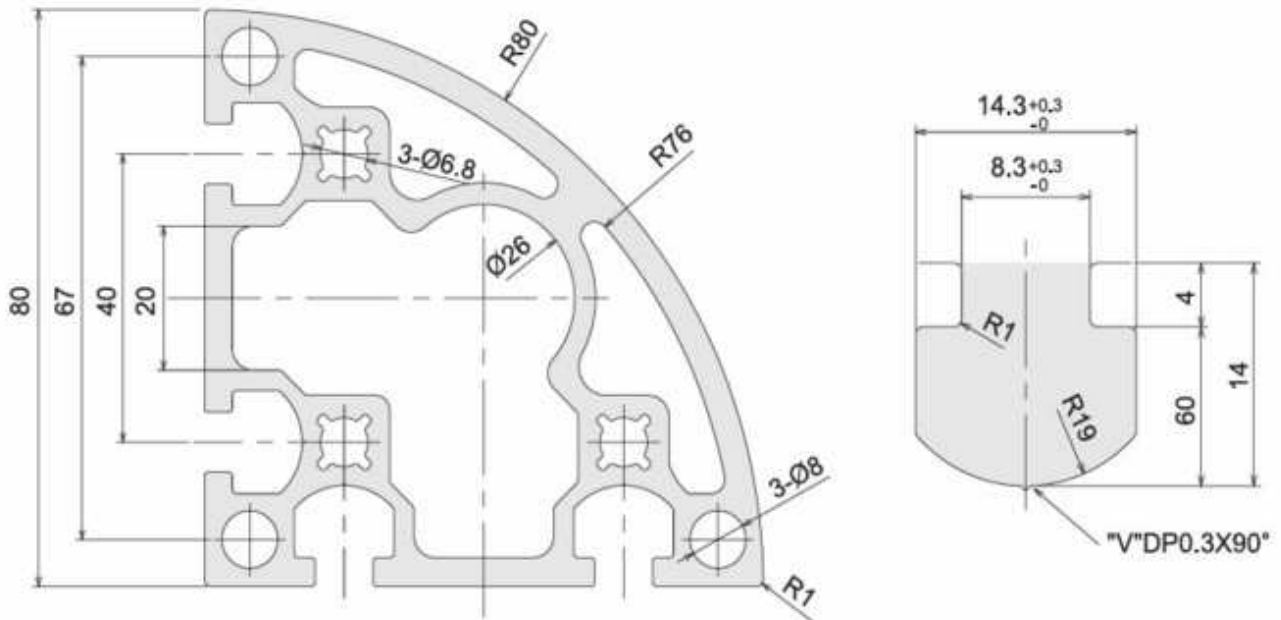

Technical Data (技術 Data)	
Material (材質)	A6N01S-T5 or A6063S-T5
Surface Processing (表面處理)	Anodized 陽極電鍍
Weight (重量)	4.69kg/m
Section Area (斷面積)	1,732.02mm ²
Second Section Moment	I _x =74.495x10cm
斷面2次 Moment	I _y =134.69x10cm
Specification (長度)	4,000mm / 6,000mm
Color (顏色)	Silver , Black
Application (用途)	機械結構、工作桌、機器外觀美化

鋁擠型配件 鉸鏈

RX-HTA40A

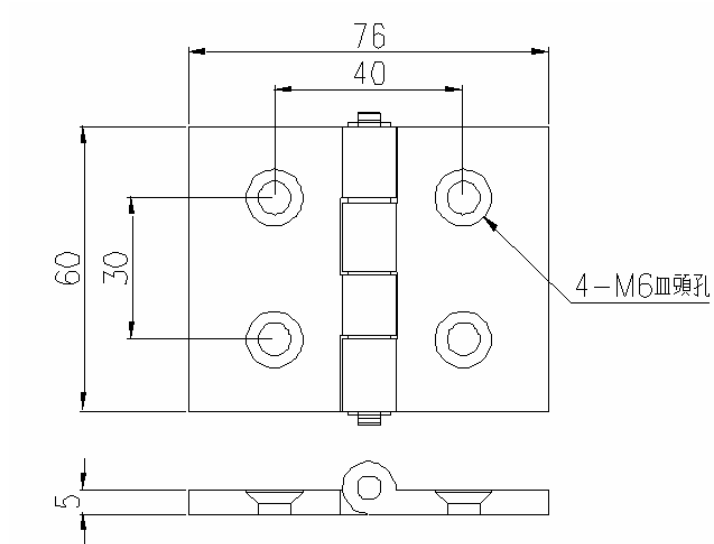

RX-HTA35A

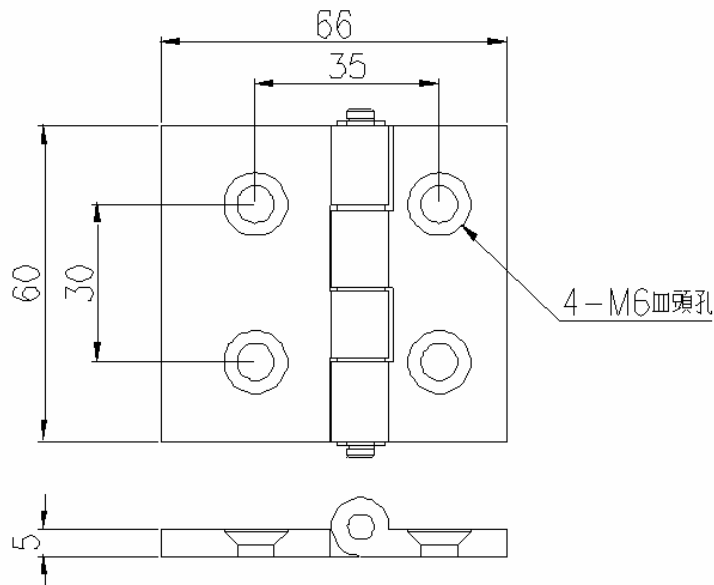

RX-HTA30A

鋁擠型配件 鉸鏈

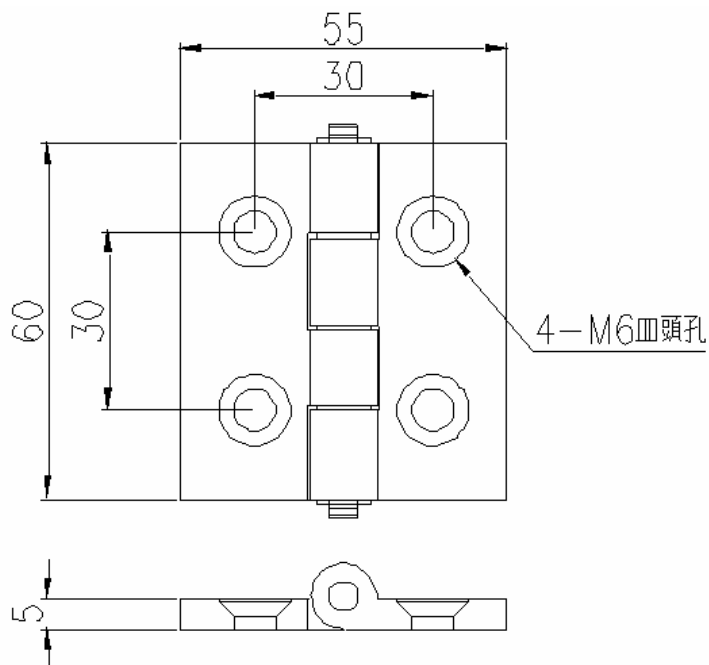

HW-001

鋁擠型配件 磁鐵

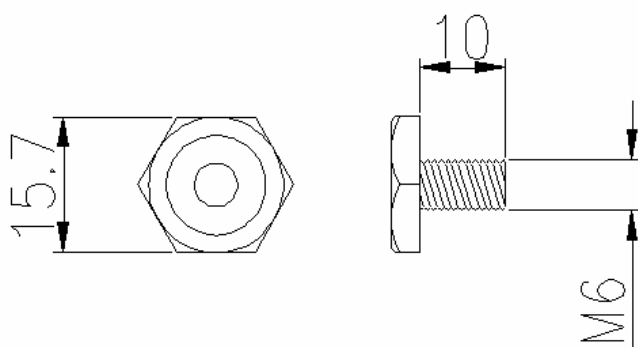

Z1F-HMB306T

鋁擠型配件 封板器

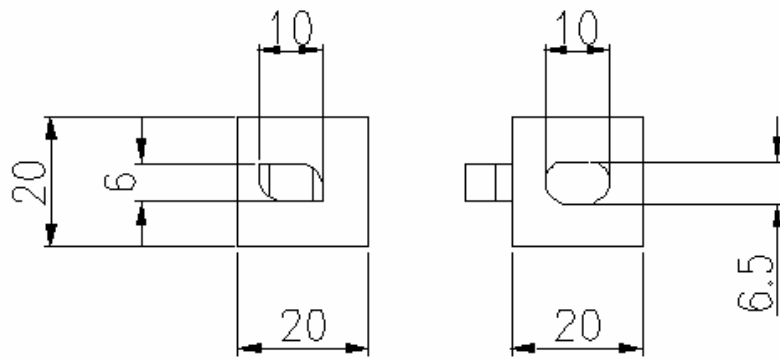

Z1F-HMB406T

鋁擠型配件 封板器

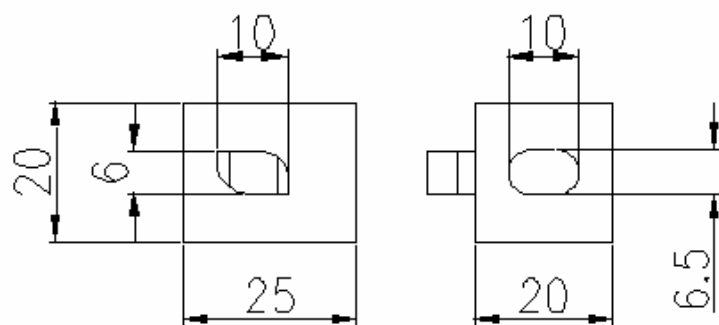

1G-738-117

鋁擠型配件 把手

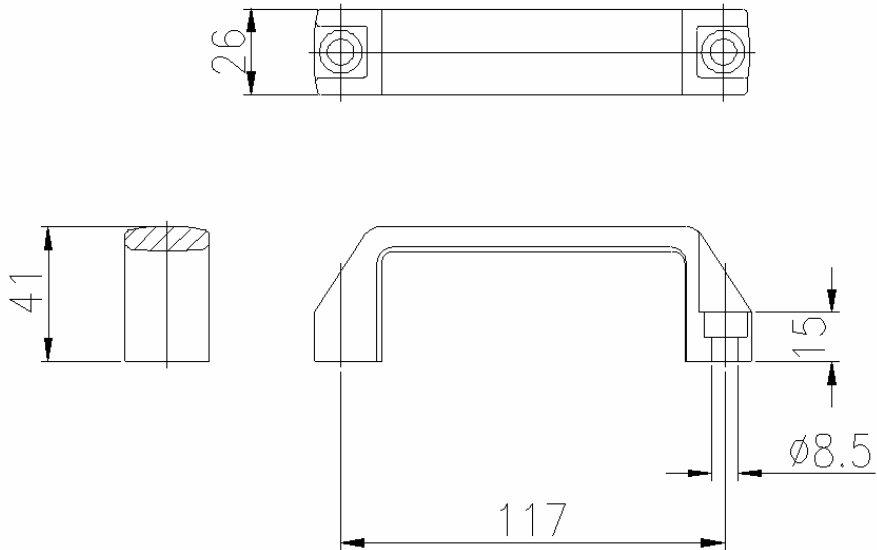

1G-00746-2

鋁擠型配件 把手

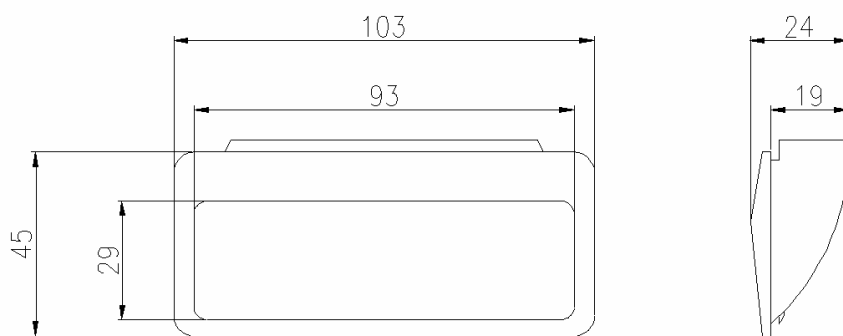

1G-118-57

鋁擠型配件 把手

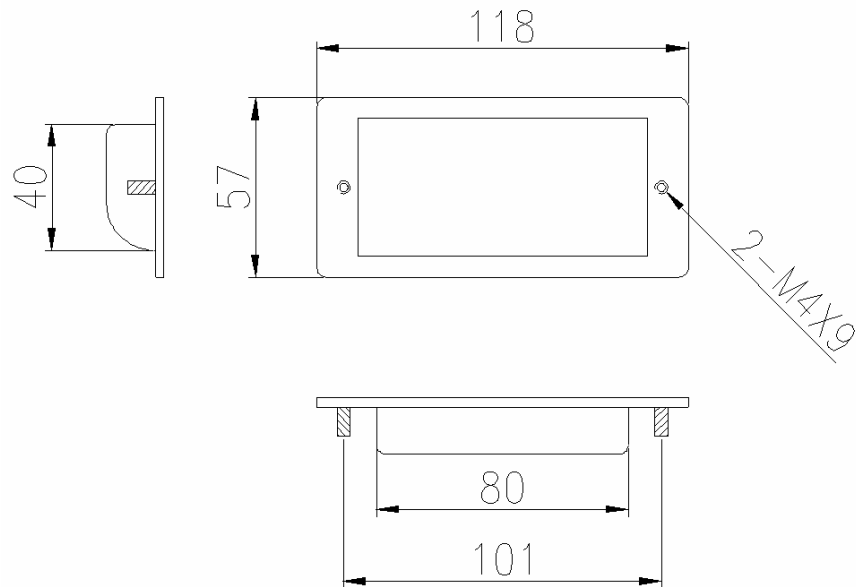

XRF-HDR1530

鋁擠型配件 連接件

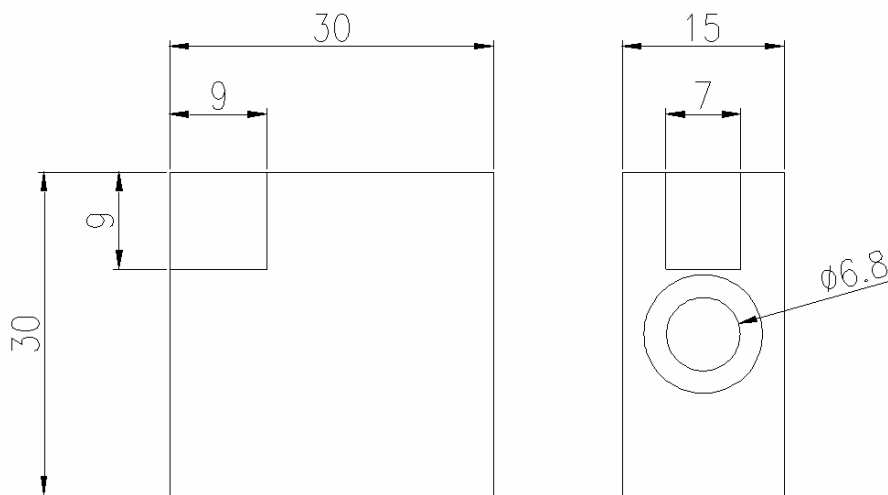

XRF-HCN2020

鋁擠型配件 連接件

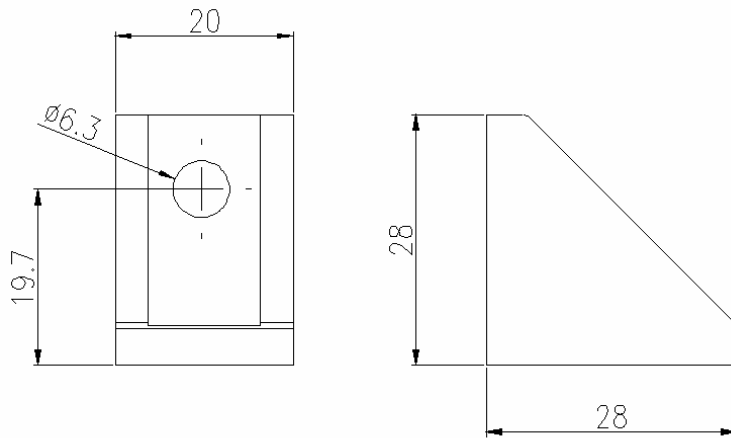

XRF-HCN2430

鋁擠型配件 連接件

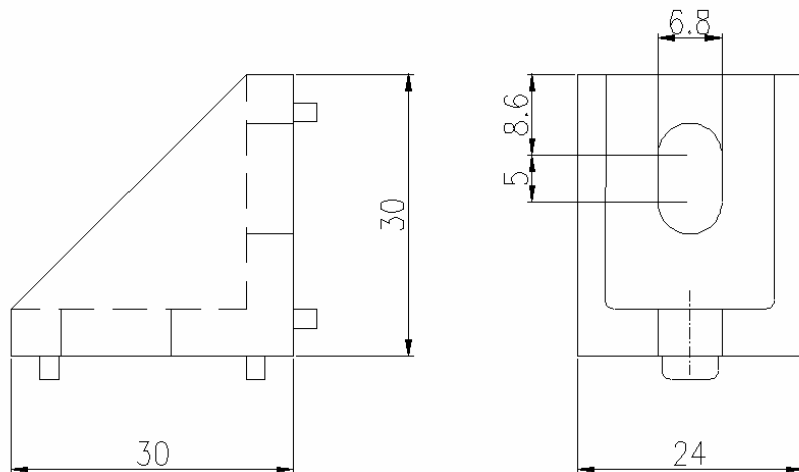

XRF-HCN3040

鋁擠型配件 連接件

